

# Shaft Coupling Bore Additional Modification Service 1/2

## Service Contents

- Bores, keyways, and set screw holes can be machined in the shaft coupling.
- Select from nine modification types.

## Applicable Products

Flexible Flanged Shaft Couplings

## Fees • Delivery

- Please feel free to contact us.

## Part Number Specification

**FCL90-18-BKW-H8 N -19-BKT-G6 N**

Shaft Couplings Part Number **1** **2** **3** **4** **5** **6** **7** **8**

Select the following eight items.

- |              |                            |           |                            |
|--------------|----------------------------|-----------|----------------------------|
| Bushing Side | <b>1</b> Bore Diameter     | Bolt Side | <b>5</b> Bore Diameter     |
|              | <b>2</b> Modification Type |           | <b>6</b> Modification Type |
|              | <b>3</b> Bore Tolerance    |           | <b>7</b> Bore Tolerance    |
|              | <b>4</b> Keyway Standard   |           | <b>8</b> Keyway Standard   |

\*For large order quantities, please contact our customer service.

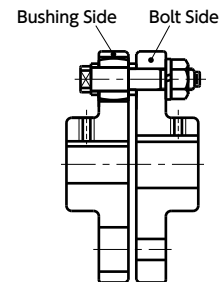

## Order Process

- Specify the bore diameter within the range of the minimum bore diameter \*1 or more and the maximum bore diameter \*2 or less of the shaft coupling. **1** **5**

\*1: In principle, the minimum bore diameter is the length of the shaft coupling (dimension L) × 1/3.

\*2: For the maximum bore diameter, refer to the dimension tables on each product page.

For bore diameters exceeding 130 mm, please contact our customer service.

- Select the modification type.

Refer to the Modification Type List on the next page and specify the symbol inside . **2** **6**

\*If set screw hole modification (modification types **BNS** **BNW** **BNT** **BKS** **BKW** **BKT**) is specified, set screws will be supplied.

- Select the bore tolerance and specify the modification symbol. **3** **7**

Tolerance Region	Tolerance Class/Modification Symbol		
	Class 6	Class 7	Class 8
H	<b>H6</b>	<b>H</b>	<b>H8</b>
G	<b>G6</b>	<b>G</b>	<b>G8</b>
F	<b>F6</b>	<b>F</b>	<b>F8</b>

\*Class 7 is standard. Specify Classes 6 or 8 with dimension tolerance symbols.

\*Please contact our customer service for bore tolerances other than the above.

- Fitting example of the shaft coupling shaft and bore

Shaft Diameter Tolerance	Bore Diameter Tolerance
h6	JS6*1 · H7
j6 · k6	H6 · H7
m6	G6 · H7

\*1: Not covered by the additional modification service.

- For keyway modification, select the keyway standard.

- Parallel keyway (modification types **BKN** **BKS** **BKW** **BKT**)

Specify the modification symbol according to the parallel key standard. **4** **8**

Parallel Keyway Standards	Modification Symbol
New JIS Parallel Keyway	<b>N</b>
Former JIS Parallel Keyway	<b>Q</b>

\*Refer to next page for the keyway specifications.

- Taper keyway (modification type **BCN**)
- Specify the modification symbol according to the taper key standard. **4** **8**

Taper Keyway Standards	Modification Symbol
New JIS Taper Keyway	<b>NS</b>
Former JIS Taper Keyway	<b>QS</b>

\*Refer to next page for the keyway specifications.

## Modification Type List

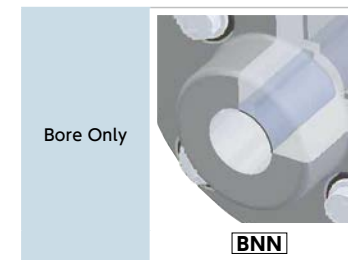

### • Bore + Keyway

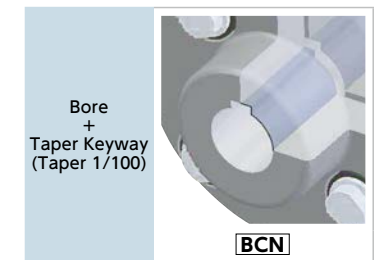
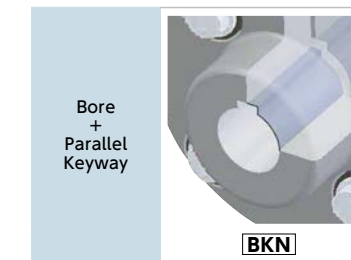

### • Bore + Set Screw Hole

	Number/Position of Set Screw Holes		
	1 Place	2 Places (arranged at 90°)	2 Places (arranged at 120°)
Bore + Set Screw Hole	<b>BNS</b>	<b>BNW</b>	<b>BNT</b>
Bore + Set Screw Hole + Parallel Keyway	<b>BKS</b>	<b>BKW</b>	<b>BKT</b>

\* If set screw hole modification (modification types **BNS** **BNW** **BNT** **BKS** **BKW** **BKT**) is specified, set screws will be supplied.



# Shaft Coupling Bore Additional Modification Service 2/2

## Dimensions

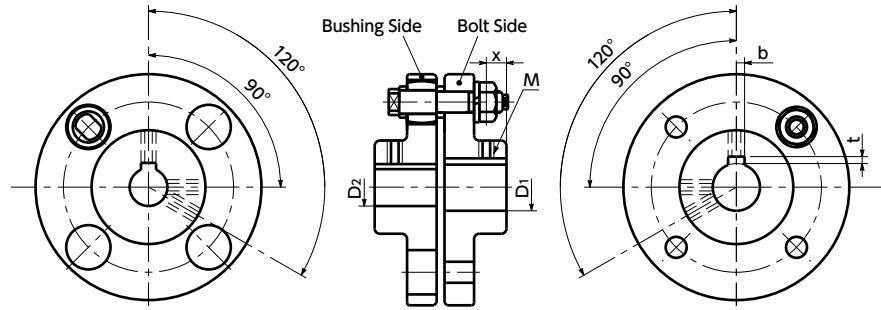

- Bore  $D_1$   $D_2$  : Specify within the range of the minimum bore diameter \*1 or more and the maximum bore diameter \*2 or less of the shaft coupling.

\*1: In principle, the minimum bore diameter is the length of the shaft coupling (dimension L)×1/3.

\*2: For the maximum bore diameter, refer to the dimension tables on each product page.  
For bore diameters exceeding 130 mm, please contact our customer service.

- Keyway  $b$   $t$  : Keyways will be machined according to the JIS standard.
- Set screw  $M$  : Set as shown below according to the bore diameter.
- $x$  : Dimension x from the end face of the hub to the center of the set screw is 1.5 times the thread diameter as a reference.

⚠ The size and position of the set screw may differ depending on the type of shaft coupling.

Standard Bore Diameter $D_1$ and $D_2$		Keyway				Key		Set Screw* $M$
Over	or Less	b		t		Nominal Dimension $b \times h$		
		Reference Dimensions	Allowance (JS9)	Reference Dimensions	Allowance			
-	10	3	±0.0125	1.4	+0.1 0	3×3	M6	
10	12	4	±0.0150	1.8	+0.1 0	4×4	M6	
12	17	5	±0.0150	2.3	+0.1 0	5×5	M6	
17	22	6	±0.0150	2.8	+0.1 0	6×6	M6	
22	30	8	±0.0180	3.3	+0.2 0	8×7	M8	
30	38	10	±0.0180	3.3	+0.2 0	10×8	M8	
38	44	12	±0.0215	3.3	+0.2 0	12×8	M8	
44	50	14	±0.0215	3.8	+0.2 0	14×9	M10	
50	58	16	±0.0215	4.3	+0.2 0	16×10	M10	
58	65	18	±0.0215	4.4	+0.2 0	18×11	M12	
65	75	20	±0.0260	4.9	+0.2 0	20×12	M12	
75	85	22	±0.0260	5.4	+0.2 0	22×14	M12	
85	95	25	±0.0260	5.4	+0.2 0	25×14	M12	
95	110	28	±0.0260	6.4	+0.2 0	28×16	M12	
110	130	32	±0.0310	7.4	+0.2 0	32×18	M12	

\*The size of the set screw may differ depending on the type of shaft coupling.

• Excerpt from JIS B 1301 - 1996

Standard Bore Diameter $D_1$ and $D_2$		Keyway				Key		Set Screw* $M$
Over	or Less	b		t		Nominal Dimension $b \times h$		
		Reference Dimensions	Allowance (F7)	Reference Dimensions	Allowance			
-	10	4	+0.022 +0.010	1.5	+0.1 0	4×4	M6	
10	13	4	+0.022 +0.010	1.5	+0.1 0	4×4	M6	
13	20	5	+0.022 +0.010	2	+0.1 0	5×5	M6	
20	30	7	+0.028 +0.013	3	+0.1 0	7×7	M8	
30	40	10	+0.028 +0.013	3.5	+0.1 0	10×8	M8	
40	50	12	+0.034 +0.016	3.5	+0.1 0	12×8	M10	
50	60	15	+0.034 +0.016	5	+0.1 0	15×10	M10	
60	70	18	+0.034 +0.016	6	+0.1 0	18×12	M12	
70	80	20	+0.041 +0.020	6	+0.1 0	20×13	M12	
80	95	24	+0.041 +0.020	8	+0.1 0	24×16	M12	
95	110	28	+0.041 +0.020	9	+0.1 0	28×18	M12	
110	125	32	+0.050 +0.025	10	+0.1 0	32×20	M12	
125	140	35	+0.050 +0.025	11	+0.1 0	35×22	M12	

\*The size of the set screw may differ depending on the type of shaft coupling.

• Excerpt from JIS B 1301 - 1959

## Inspection

- Bores (all)  
Inspection by limit plug gauge or cylinder gauge
- Keyways (first item)  
Keyway width: Inspection by limit key width gauge  
Keyway depth: Inspection by calipers
- Set screw holes (first item)  
Set screw diameter: Inspection by limit gauge for screws

Standard Bore Diameter* $D_1$ and $D_2$		Keyway				Key	
Over	or Less	b		t		Nominal Dimension $b \times h$	
		Reference Dimensions	Allowance (D10)	Reference Dimensions	Allowance		
-	12	4	+0.078 +0.030	1.2	+0.1 0	4×4	
12	17	5	+0.078 +0.030	1.7	+0.1 0	5×5	
17	22	6	+0.078 +0.030	2.2	+0.1 0	6×6	
22	30	8	+0.098 +0.040	2.4	+0.2 0	8×7	
30	38	10	+0.098 +0.040	2.4	+0.2 0	10×8	
38	44	12	+0.120 +0.050	2.4	+0.2 0	12×8	
44	50	14	+0.120 +0.050	2.9	+0.2 0	14×9	
50	58	16	+0.120 +0.050	3.4	+0.2 0	16×10	
58	65	18	+0.120 +0.050	3.4	+0.2 0	18×11	
65	75	20	+0.149 +0.065	3.9	+0.2 0	20×12	
75	85	22	+0.149 +0.065	4.4	+0.2 0	22×14	
85	95	25	+0.149 +0.065	4.4	+0.2 0	25×14	
95	110	28	+0.149 +0.065	5.4	+0.2 0	28×16	
110	130	32	+0.180 +0.080	6.4	+0.2 0	32×18	

\*The standard bore diameter is  $\phi$  12 or more and does not include decimal points.

• The taper of the keyway is 1/100.

• Excerpt from JIS B 1301 - 1996

Standard Bore Diameter* $D_1$ and $D_2$		Keyway				Key	
Over	or Less	b		t		Nominal Dimension $b \times h$	
		Reference Dimensions	Allowance (D10)	Reference Dimensions	Allowance		
-	13	4	+0.078 +0.030	1.5	+0.1 0	4×4	
13	20	5	+0.078 +0.030	2	+0.1 0	5×5	
20	30	7	+0.098 +0.040	3	+0.1 0	7×7	
30	40	10	+0.098 +0.040	3.5	+0.1 0	10×8	
40	50	12	+0.120 +0.050	3.5	+0.1 0	12×8	
50	60	15	+0.120 +0.050	5	+0.1 0	15×10	
60	70	18	+0.120 +0.050	6	+0.1 0	18×12	
70	80	20	+0.149 +0.065	6	+0.1 0	20×13	
80	95	24	+0.149 +0.065	8	+0.1 0	24×16	
95	110	28	+0.149 +0.065	9	+0.1 0	28×18	
110	125	32	+0.180 +0.080	10	+0.1 0	32×20	
125	140	35	+0.180 +0.080	11	+0.15 0	35×22	

\*The standard bore diameter is  $\phi$  12 or more and does not include decimal points.

• The taper of the keyway is 1/100.

• Excerpt from JIS B 1301 - 1959