

六角ナットの形状・寸法

仕上げ程度：中(M6未満は仕上げ程度：上)

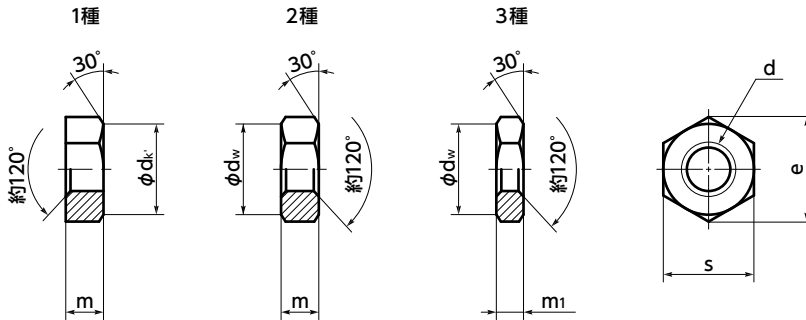

単位：mm

ねじの呼び (d)		m		m1		s		e	φdw・φdk'
並目	細目	基準寸法	許容差	基準寸法	許容差	基準寸法	許容差	約	約
M2	—	1.6	0	1.2	0	4	0	4.6	3.8
M2.5	—	2		1.6		5		5.8	4.7
M3	—	2.4	-0.25	1.8	-0.25	5.5	-0.2	6.4	5.3
(M3.5)	—	2.8	0	2	6	6.9		5.8	
M4	—	3.2		2.4	7	8.1	6.8		
M5	—	4	-0.30	3.2	0 -0.3	8	0	9.2	7.8
M6	—	5	0	3.6	0	10	-0.6	11.5	9.8
(M7)	—	5.5	-0.48	4.2	-0.48	11	0	12.7	10.8
M8	M8×1	6.5	0	5	-0.7	13	0	15	12.5
M10	M10×1.25	8		6		17	19.6	16.5	
M12	M12×1.25	10	-0.58	7	0	19	-0.8	21.9	18
(M14)	(M14×1.5)	11	0	8	-0.58	22		0	25.4
M16	M16×1.5	13		10	24	-0.8	27	0	27.7
(M18)	(M18×1.5)	15	-0.70	11	0	30	-1.0	31.2	26
M20	M20×1.5	16	0	12		32		34.6	29
(M22)	(M22×1.5)	18		13	36	0	37	31	
M24	M24×2	19	-0.84	14	-0.70	41	-1.2	41.6	34
(M27)	(M27×2)	22		16	46	0		47.3	39
M30	M30×2	24	0	18	-0.84	50	-1.4	53.1	44
(M33)	(M33×2)	26	-0.84	20		55		57.7	48
M36	M36×3	29	0	21	0	60	-1.0	63.5	53
(M39)	(M39×3)	31		23		65		69.3	57
M42	—	34	-1.0	25	-0.84	70	-1.2	75	62
(M45)	—	36		27	75	80.8		67	
M48	—	38	0	29	-1.0	80	-1.4	86.5	72
(M52)	—	42	-1.0	31		85		92.4	77
M56	—	45	0	34	-1.0	90	-1.4	98.1	82
(M60)	—	48		36		95		104	87
M64	—	51	0 -1.2	38	0	95	0	110	92

備考 ねじの呼びに括弧を付けたものは、なるべく用いない。